

Profilmesserkopf
Porte-outils crantés
Corrugated cutter heads

MEC

4.070

D	B	d	nmax	Z2	Z4
100	40	30	9000	300.-	380.-
100	60	30	9000	340.-	430.-
100	80	30	9000	380.-	480.-
100	100	30	9000	430.-	540.-
100	130	30	9000	480.-	600.-
122	40	30/40	8000	300.-	380.-
122	60	30/40	8000	340.-	430.-
122	80	30/40	8000	380.-	480.-
122	100	30/40	8000	430.-	540.-
122	130	30/40	8000	480.-	600.-
122	150	30/40	8000	530.-	660.-
122	180	40	8000		770.-
122	230	40	8000		950.-
137	50	40/50	7000		420.-
137	60	40/50	7000		450.-
137	80	40/50	7000		500.-
137	100	40/50	7000		600.-
137	130	40/50	7000		690.-
137	150	40/50	7000		760.-
137	180	40/50	7000		850.-
137	230	40/50	7000		935.-

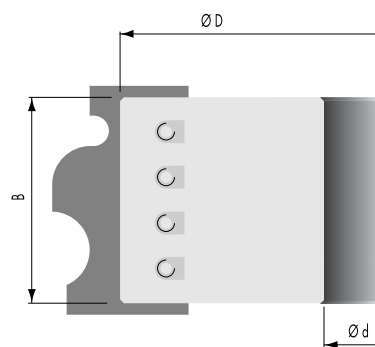

HSS Messerblanketten mit Rückenverzahnung
Couteaux bruts avec crantage en HSS
HSS corrugated back knives

MEC

4.071

B	D	H 40 tmax 8	H 50 tmax 17	H 60 tmax 27	H 70 tmax 37	H 80 tmax 47
40	8	18.-	20.-	23.-	26.-	38.-
50	8	22.-	24.-	27.-	32.-	43.-
60	8	26.-	28.-	32.-	37.-	48.-
80	8	34.-	37.-	43.-	45.-	58.-
100	8	41.-	45.-	47.-	55.-	68.-
130	8	51.-	56.-	60.-	69.-	83.-
150	8	60.-	65.-	72.-	87.-	102.-
180	8	70.-	77.-	82.-	94.-	112.-
230	8	89.-	97.-	106.-	120.-	136.-
650	8	200.-	220.-	240.-	260.-	400.-



Profilschleifen pro mm – Profilé par mm – Profile grinding per mm

	B 40 +	B 60 +	B 80 +	B 100 +	B 150 +
Einfache Profile/Profils simples I	1.80	1.50	1.30	1.10	-.90
Komplizierte Profile/Compliqués II	1.90	1.70	1.50	1.30	1.10
Komplizierte Profile/Compliqués III	2.20	1.90	1.70	1.50	1.30

Einzelmesser + 60% – Prix pour un seul couteaux + 60% – Single knife + 60%

Abweiser + 80% – Limiteurs + 80% – chip limit + 80%

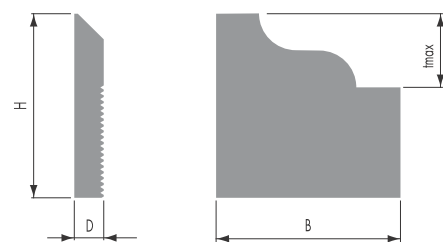

Profilmesserkopf mit Abweiser
Porte-outils crantés avec limiteur
Corrugated cutter heads with chip limit

MAN 4.070 M

Messerkopf mit Spanbegrenzer für rückenverzahnte Messer mit Anschlag-
 schraube für eine rasche und genaue Positionierung der Messer und Abweiser
 Porte-outil avec limiteur pour couteaux crantés. Arrêt longitudinal pour
 permettre un positionnement rapide et précis des couteaux et limiteurs
 Cutter head with chip limit for corrugated back knives with positioning screw
 for fast and precise setting of knives



D	B	d	Z	n	tmax 27 mm
125	40	30	2	6000–8000	360.–
125	50	30	2	6000–8000	380.–
125	60	30	2	6000–8000	400.–
125	80	30	2	6000–8000	450.–
125	100	30	2	6000–8000	500.–
125	130	30	2	6000–8000	560.–

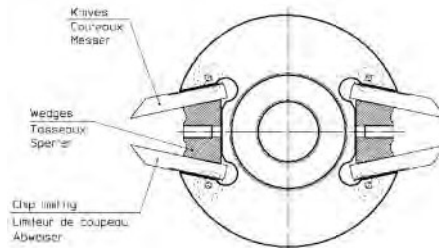
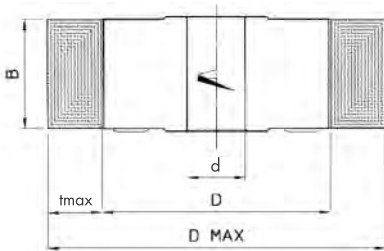

WS Spiral-Kopierfräser ohne Kugellager-Anlauftring
Porte-outils calibreur à coupe biaisée sans roulement guidabille
Helical planing cutter heads without ball bearing guide

MAN 4.092

D	B	d	Z	n	HM	WS 9.115
80	60	30	12	9600–16700	430.–	9.50
80	80	30	16	9600–16700	470.–	9.50
80	100	30	20	9600–16700	560.–	9.50
80	120	30	24	9600–16700	630.–	9.50
100	80	30	24	7700–13300	590.–	9.50
100	100	30	30	7700–13300	700.–	9.50
100	130	30	24	7700–13300	790.–	9.50
125	130	40	36	6100–10000	850.–	9.50
125	230	40	60	6100–10000	1300.–	9.50



Komplett mit Kugellager-Anlauftring
Complet avec roulement guidabille
Complete with ball bearing guide

D	B	d	Z	n	HM	WS 9.115
55	80	30	16	9600–16700	530.–	9.50
62	80	30	16	9600–16700	530.–	9.50
62	100	30	20	9600–16700	600.–	9.50
62	130	30	24	9600–16700	690.–	9.50